

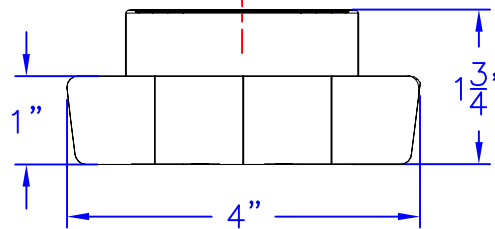

Technical Data

S-4532-XX

DOUBLE HOOK

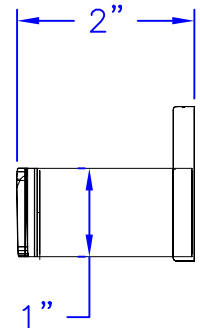
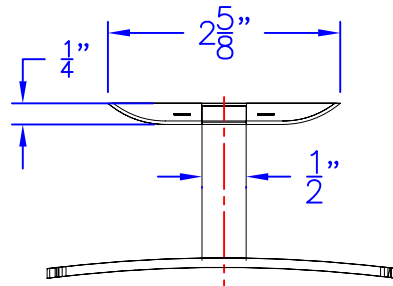
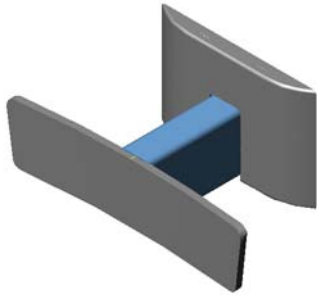

FINISHES:

- SS SATIN STAINLESS
- BS BRIGHT STAINLESS
- PC POWDER COAT (SPECIFY COLOR)

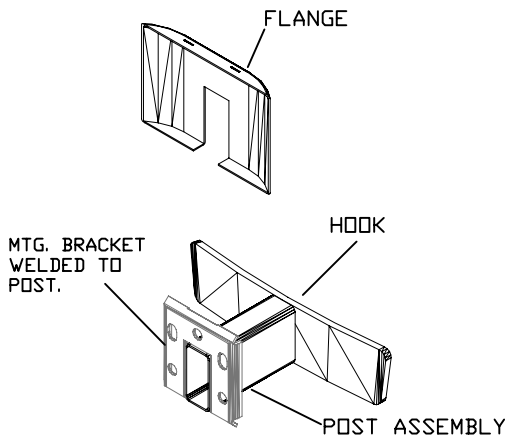

Construction:

POST ASSEMBLY: 22 GAUGE TYPE 304 STAINLESS STEEL
 MOUNTING BRACKET: 19 GAUGE TYPE 304 STAINLESS STEEL WITH (3) $\frac{3}{16}$ " ϕ AND (2) $\frac{3}{16}$ " X $\frac{9}{32}$ " SLOTTED HOLES.
 HOOK: 13 GAUGE TYPE 304 STAINLESS STEEL STAMPED
 MOUNTING SCREWS: #8 X 1 $\frac{1}{4}$ " PHIL. PAN HD. ZINC PLATE
 FINISHES AS NOTED.

Installation:

USE MOUNTING BRACKET (WELDED TO POST ASSEMBLY) TO MARK AND LOCATE HOLES, FASTEN TO WALL.
 SLIDE FLANGE ONTO POST ASSEMBLY AND SNAP ONTO MTG. BRACKET.

CAUTION: UNIT IS ONLY AS STRONG AS THE ANCHORING DEVICES AND THE WALL ON WHICH IT IS MOUNTED TO.

Guide Specification:

DOUBLE HOOK.
 CONCEALED MOUNTING SYSTEM.
 FABRICATED FROM TYPE 304 STAINLESS STEEL.

The manufacturer reserves the right to make changes in design and material without formal notice and without incurring obligation

© Copyright 2005
 Brey-Krause Manufacturing

Brey-Krause Manufacturing
 1209 West Lehigh Street, Bethlehem, PA 18018
 Phone: 610.867.1401 Fax: 610.866.1433
 www.breykrause.com