

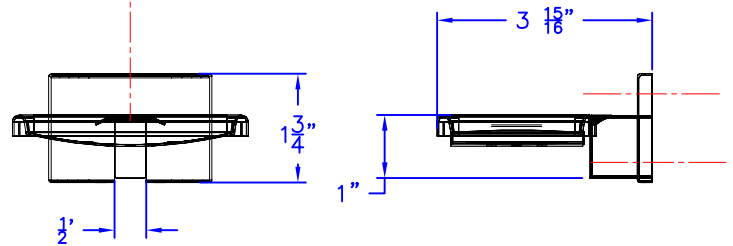

Technical Data

S-4510-XX

SOAP DISH WITH DRAIN

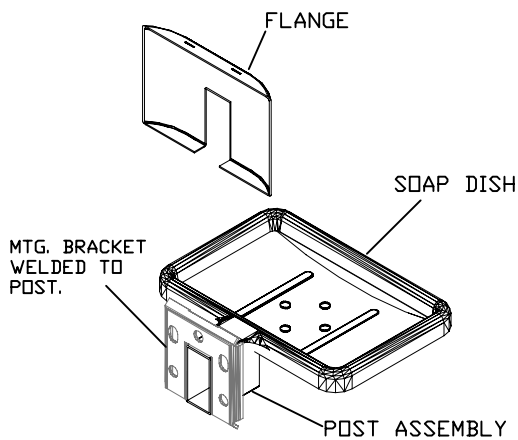
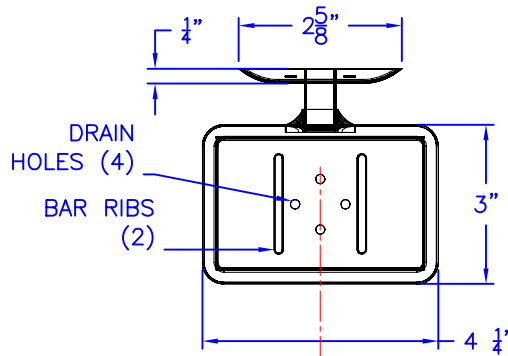
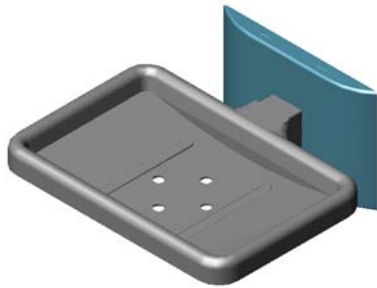

FINISHES:

- SS SATIN STAINLESS
- BS BRIGHT STAINLESS
- PC POWDER COAT (SPECIFY COLOR)

Construction:

POST ASSEMBLY: 22 GAUGE TYPE 304 STAINLESS STEEL
MOUNTING BRACKET: 19 GAUGE TYPE 304 STAINLESS STEEL WITH (3) $\frac{3}{16}$ " ϕ AND (2) $\frac{3}{16}$ " X $\frac{9}{32}$ " SLOTTED HOLES.
SOAP DISH: 22 GAUGE TYPE 304 STAINLESS STEEL STAMPED FORMED
MOUNTING SCREWS: #8 X 1 $\frac{1}{4}$ " PHIL. PAN HD. ZINC PLATE
FINISHES AS NOTED.

Installation:

USE MOUNTING BRACKET (WELDED TO POST ASSEMBLY) TO MARK AND LOCATE HOLES, FASTEN TO WALL.
SLIDE FLANGE ONTO POST ASSEMBLY AND SNAP ONTO MTG. BRACKET.

CAUTION: UNIT IS ONLY AS STRONG AS THE ANCHORING DEVICES AND THE WALL ON WHICH IT IS MOUNTED TO.

Guide Specification:

SINGLE BAR SOAP HOLDER.
CONCEALED MOUNTING SYSTEM.
FABRICATED FROM TYPE 304 STAINLESS STEEL.