

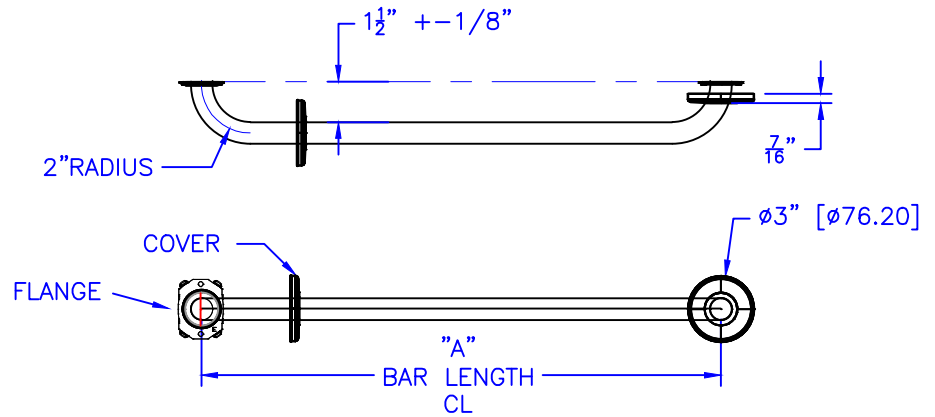

Technical Data

D-76XX-XX

1" STRAIGHT GRAB BAR

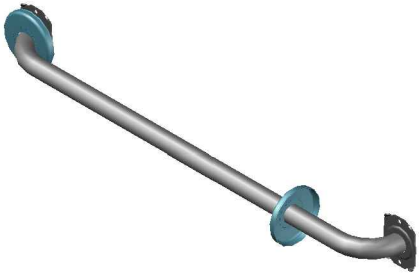

FLANGE DETAIL

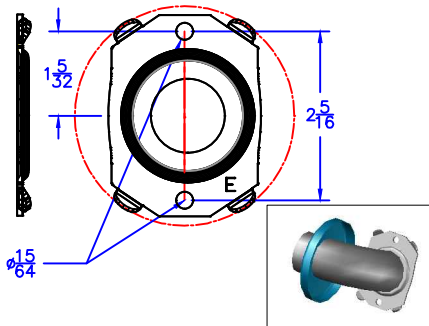

FLANGE #	BAR # (LENGTH)	FINISH	GRIP
D-76	- XX	- XX	- XX
BAR # (LENGTHS)			
-10	12"	FINISHES:	
-11	16"	-SS	SATIN STAINLESS
-12	18"	-BS	BRIGHT STAINLESS
-13	24"	-SS-P	SATIN STAINLESS WITH PEEN SAFETY GRIP
-21	30"	-BS-P	BRIGHT STAINLESS WITH PEEN SAFETY GRIP
-14	32"	-SS-K	SATIN STAINLESS WITH KNURL SAFETY GRIP
-15	42"	-BS-K	BRIGHT STAINLESS WITH KNURL SAFETY GRIP
-16	36"	-<PC)	POWDER COAT - SPECIFY COLOR
-17	48"		

PEEN AND KNURL GRIPS WILL BE APPLIED TO STRAIGHT SECTION OF GRAB BAR ONLY.

Construction:

- TUBING:** 1" ϕ X 18 GAUGE, TYPE 304 STAINLESS STEEL. MANDREL BENT TUBE ENDS PASS THROUGH FLANGES AND ARE TIG WELDED TO FORM A SINGLE STRUCTURE UNIT. WALL CLEARANCE IS 1 1/2".
- FLANGES:** 14 GAUGE, TYPE 304 STAINLESS STEEL WITH (2) 15/64 HOLES FOR ATTACHING TO WALL.
- COVERS:** 22 GAUGE, TYPE 304 STAINLESS STEEL, 3" DIAMETER X 1/2" DEEP. EACH COVER SNAPS OVER FLANGE TO CONCEAL MOUNTING SCREWS.

STRENGTH:

BREY-KRAUSE GRAB BARS WITH 1 1/2" WALL CLEARANCE MEET AND EXCEED ADA LOAD REQUIREMENTS OF 250 POUNDS WHEN PROPERLY INSTALLED.

CAUTION: A GRAB BAR IS ONLY AS STRONG AS THE ANCHORING DEVICES AND THE WALL ON WHICH IT IS MOUNTED TO.

Installation:

SECURE GRAB BAR TO WALL WHERE ADEQUATE IN-WALL BACKING EXISTS. POSITION BAR HORIZONTALLY SO THAT THE GRIPPING SURFACE IS 33" TO 36" ABOVE FINISHED FLOOR. USE GRAB BAR AS TEMPLATE TO LOCATE MOUNTING HOLES. DRILL HOLES AND SET ANCHORS. MOUNT GRAB BAR TO WALL AND SECURE MOUNTING SCREWS. SNAP COVERS OVER FLANGES. GRAB BAR MOUNTING KITS ARE AVAILABLE.

Guide Specification:

GRAB BAR IS FABRICATED OF 304 STAINLESS STEEL WITH CONCEALED MOUNTING FLANGES AND SNAP ON COVERS IN SIZE AND CONFIGURATION INDICATED