

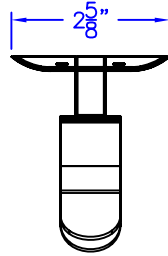

Technical Data

S-4535-XX

HAT AND COAT HOOK

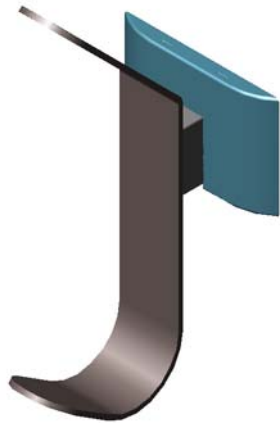

FINISHES:

- SS SATIN STAINLESS
- BS BRIGHT STAINLESS
- PC POWDER COAT (SPECIFY COLOR)

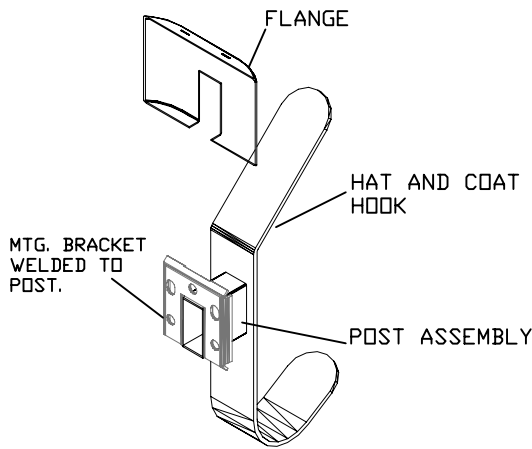
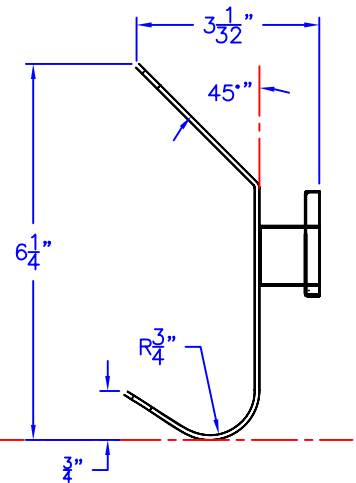
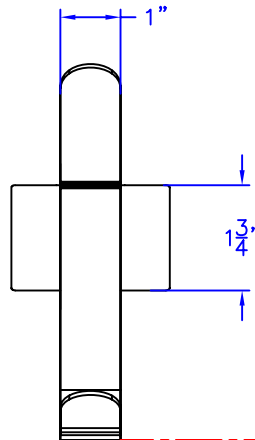

Construction:

POST ASSEMBLY: 22 GAUGE TYPE 304 STAINLESS STEEL
 MOUNTING BRACKET: 19 GAUGE TYPE 304 STAINLESS STEEL WITH (3) $\frac{3}{16}$ " ϕ AND (2) $\frac{3}{16}$ " X $\frac{9}{32}$ " SLOTTED HOLES.
 HOOK: 14 GAUGE TYPE 304 STAINLESS STEEL
 MOUNTING SCREWS: #8 X 1 $\frac{1}{4}$ " PHIL. PAN HD. ZINC PLATE
 FINISHES AS NOTED.

Installation:

USE MOUNTING BRACKET (WELDED TO POST ASSEMBLY) TO MARK AND LOCATE HOLES, FASTEN TO WALL.
 SLIDE FLANGE ONTO POST ASSEMBLY AND SNAP ONTO MTG. BRACKET.

CAUTION: UNIT IS ONLY AS STRONG AS THE ANCHORING DEVICES AND THE WALL ON WHICH IT IS MOUNTED TO.

Guide Specification:

HAT AND COAT HOOK.
 CONCEALED MOUNTING SYSTEM.
 FABRICATED FROM TYPE 304 STAINLESS STEEL.

The manufacturer reserves the right to make changes in design and material without formal notice and without incurring obligation

© Copyright 2005
 Brey-Krause Manufacturing

Brey-Krause Manufacturing
 1209 West Lehigh Street, Bethlehem, PA 18018
 Phone: 610.867.1401 Fax: 610.866.1433
 www.breykrause.com