

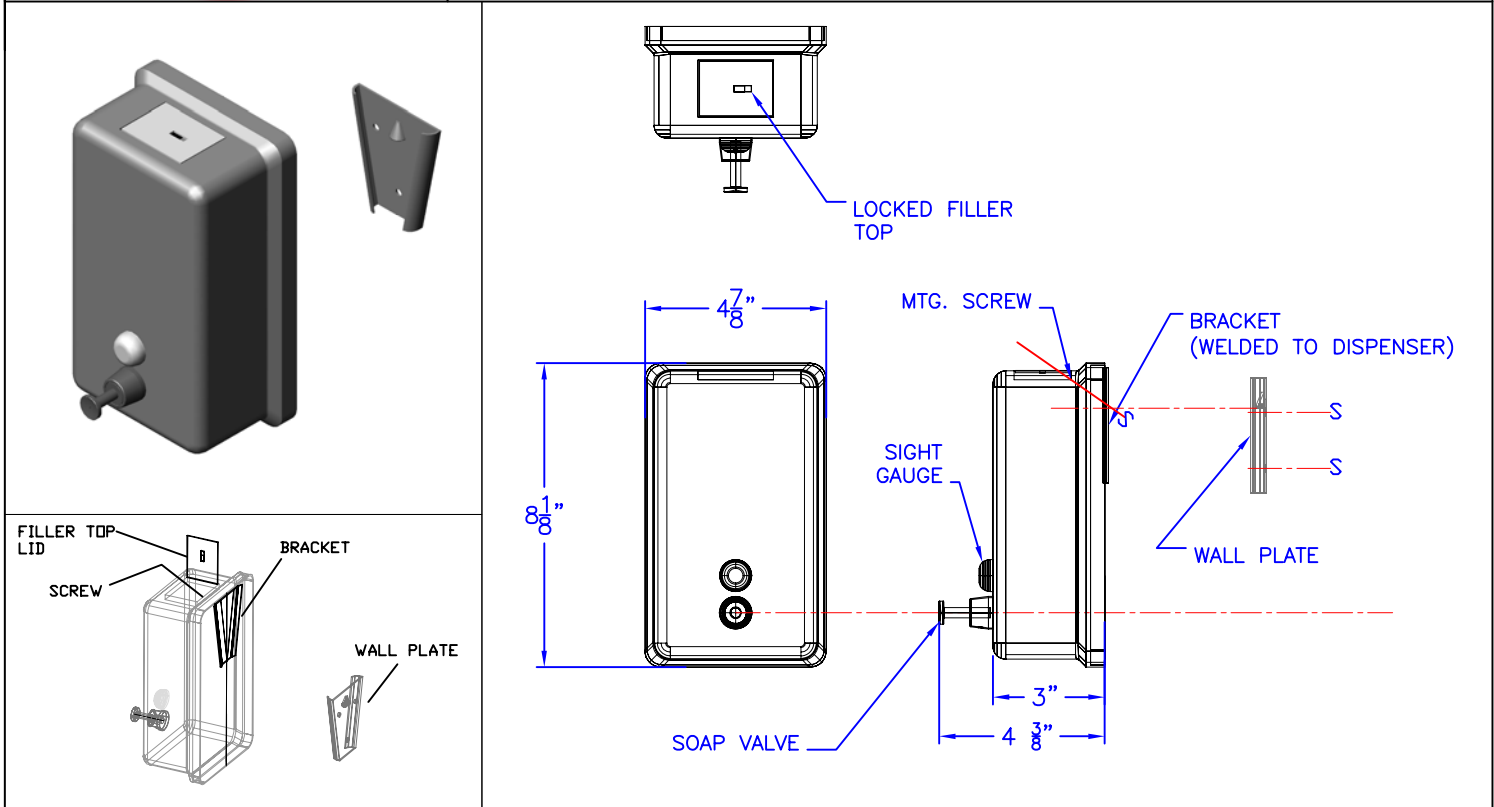

Technical Data

S-0121-SS

VERTICAL MOUNT 40 OZ. LIQUID SOAP DISPENSER



Construction:

BODY: 20 GAUGE STAINLESS STEEL WITH EXPOSED SURFACES IN SATIN #4 FINISH. MOUNTING BRACKET IS WELDED TO BACK.
 WALL PLATE: 20 GAUGE STAINLESS STEEL WITH (3) MOUNTING HOLES.
 SOAP VALVE: CHROME PLATED HOUSING WITH ABS CHROME PLATED PLASTIC MECHANISM.

Operation:

PUSH IN SOAP VALVE DISPENSES MEASURED AMOUNT OF LIQUID SOAP.
 SIGHT GAUGE INDICATES REFILL TIME.
 LOCKED FILLER TOP OPENS WITH SPECIAL KEY.

Installation:

USE UNIT TO MARK AND LOCATE AT DESIRED HEIGHT.
 MOUNT WALL PLATE TO WALL USING SUPPLIED SCREWS (3).
 SLIDE UNIT ONTO WALL PLATE (FROM TOP DOWN TO FLOOR).
 UNLOCK TOP FILLER PLATE AND DRIVE SCREW INTO WALL PLATE.
 FILL BODY WITH LIQUID SOAP & LOCK TOP FILLER PLATE.

Guide Specification:

VERTICAL CONCEALED MOUNTED LIQUID SOAP DISPENSER.
 20 GAUGE #4 SATIN STAINLESS STEEL.
 40 OZ. LIQUID CAPACITY.
 PUSH IN LIQUID SOAP VALVE.

The manufacturer reserves the right to make changes in design and material without formal notice and without incurring obligation

© Copyright 2005
 Brey-Krause Manufacturing

Brey-Krause Manufacturing
 1209 West Lehigh Street, Bethlehem, PA 18018
 Phone: 610.867.1401 Fax: 610.866.1433
 www.breykrause.com